



**DRIZORO<sup>®</sup>**

**GALVAZINC**

## SACRIFICIAL ZINC ANODES FOR GALVANIC CORROSION CONTROL IN CONCRETE



### DESCRIPTION

**DRIZORO<sup>®</sup> GALVAZINC** are sacrificial zinc anodes to be embedded in reinforced concrete for anticorrosion galvanic protection with dual function:

- Corrosion control: Significantly reduce the existing corrosion activity.
- Cathodic prevention: Prevents the initiation of new corrosion in rebars adjacent to repair areas (avoids effect of "Incipient Anod").

When properly installed in contact with rebars, the zinc anode is activated because it is embedded in both electrolytic paste **DRIZORO<sup>®</sup> GALVANIC BOND** and a special cathodic repair mortar **MAXRITE<sup>®</sup> CATHODIC**, acting as a sacrificial anode which corrodes preferentially providing galvanic protection to the surrounding rebars exposed to both chlorides and/or carbonation processes.

**DRIZORO<sup>®</sup> GALVAZINC** is supplied in two versions:

- **DRIZORO<sup>®</sup> GALVAZINC-70**: It is a 70 grams cylindrical anode suitable for corrosion control

and protection in small repair jobs and/or with low density of rebars. It is used with a direct connection to the existing rebars.

- **DRIZORO<sup>®</sup> GALVAZINC-140**: It is a 140 grams cylindrical anode suitable for applications in large repair jobs and/or with high density of rebars. It is used with conductive cables.

### APPLICATION FIELDS

- Protection of concrete structures affected by corrosion of rebars in marine environment, bridges, harbours, dams, etc.
- Protection of concrete structures affected by carbonation process in civil works.
- Maintenance of concrete structures located in industrial areas damaged by aggressive environment, acid rain, atmospheric pollution, etc.
- Repair and corrosion protection of structural concrete on vertical or overhead surfaces, without form works.

## ADVANTAGES

- Active immediately after installation, stopping rebars corrosion and concrete degradation.
- Quick and easy installation as it is a single piece, reducing the time required for installation and/or activation.
- Minimum maintenance costs. Does not require the use of electrical power sources.
- Suitable for both conventional reinforced concrete and pre- / post-tensioned concrete.
- Prevents secondary corrosion of rebars due to the so-called halo effect/incipient anode.
- Allows long-term monitoring to know its effectiveness.
- Suitable for both direct galvanic and hybrid connection.

## APPLICATION INSTRUCTIONS

### Surface preparation

**DRIZORO GALVAZINC** system is based on the principle of rebar protection using the sacrificial anode method. Thus, the anodes are inserted into holes drilled within the concrete to provide protection for the rebars located immediately adjacent to the area to be repaired.

### Installation

For the installation of the **DRIZORO® GALVAZINC** units, follow the recommendations given in EN 12696 and CEN/TS 14038 standards.

### Application

Remove unsound, damaged, or deteriorated concrete until getting structurally sound substrate by chipping with mechanical, abrasive or percussion means, sandblasting or high-pressure water, profiling the edges of the repair area perpendicular to the surface with a minimum depth of 1 cm.

Expose the rebars affected by corrosion, removing the concrete until the exposed reinforcement is not affected. Clear the rebar around the entire perimeter to be able to cover it with a minimum thickness of 1 cm of structural repair mortar.

Remove rust from rebars by metal brush, sand or shot blasting, needle gun, etc. Subsequently, wash the surface with pressurized water. The surface must be clean and free of dust, grease, loose particles, or any other substance that could negatively affect adhesion.

Before installing **DRIZORO® GALVAZINC** anodes, check the electrical continuity of the reinforcements to be protected. Thus, any loss of continuity will require additional electrical connections and/or restoration thereof by effective means.

The location of the holes for **DRIZORO® GALVAZINC** anodes will be along and/or around and also as close to the edges of the area to be repaired. The holes shall have a diameter at least 3 mm greater than the diameter of the anode, i.e., 18 mm.

Note that anodes have a maximum radius of action of 60 cm, this being the maximum distance between two adjacent anodes. However, the definitive pattern for the location of the anodes will be given by a specific design conducted under the advice of the Technical Department, considering aspects such as the rebar density, the risk of corrosion depending on the environment, the presence of carbonation-type degradation processes, etc...

Once the holes have been drilled, and the concrete has been cleaned to remove particles and other materials that could prevent the adherence of the system, the holes will be filled with water, and it will be allowed to impregnate the concrete for at least 10 minutes. After this time, the holes will be blown with air to remove unabsorbed water and/or loose particles.

Next, the holes will be filled with the electrolytic paste **DRIZORO® GALVAZINC BOND** by caulking gun, ensuring there are no air bubbles entrapped, and then the anode is inserted inside the hole so that the anode is completely embedded by the paste.

Ensure the zinc anodes will be in direct electrical contact with the exposed rebars by means of rebar tying wires and the wire provided with the anodes, resulting from that moment in the rebars passivated in galvanic mode. Finally, the area is repaired with the **MAXRITE® CATHODIC** structural repair mortar.

### Application conditions

Avoid outdoor application for the electrolytic paste **DRIZORO® GALVAZINC BOND** if rain is expected, water contact, dew condensation, etc., is expected within 24 hours. The optimum working temperature range is from 10°C to 30°C. Do not apply with substrate and/or ambient temperatures below 5°C or if lower temperatures are expected within 24 hours after application. Likewise, do not apply on frozen or flooded surfaces.

Applications at hot temperatures, strong winds and/or low relative humidity, dampen the substrate with water. Avoid direct exposure to the sun with extreme heat.

### Cleaning tools

Tools and equipment used will be cleaned with water immediately after use.

## CONSUMPTION

The estimated consumption for **DRIZORO® GALVAZINC BOND** is about 1 cartridge of 350 ml per 15 and 8 anodes of **DRIZORO® GALVAZINC 70** and **140**, respectively.

Consumption depend on the texture, porosity, and conditions of the substrate, as well as the application method. Perform an on-site test to determine your exact consumption.

## IMPORTANT INDICATIONS

- **DRIZORO® GALVAZINC** must be used combined with both the **DRIZORO® GALVAZINC BOND** electrolytic paste and the **MAXRITE® CATHODIC** structural repair mortar with cathodic performance as a full galvanic system. Do not use other types of paste and/or mortars otherwise electrical conductivity would be compromised.
- For any application not specified in this Technical Bulletin or additional information, consult our Technical Department.

## PACKAGING

**DRIZORO® GALVAZINC** is supplied as:

- **DRIZORO® GALVAZINC-70**. Cylindrical zinc anodes of 70 grams weight, 6 cm length and 12 mm diameter, supplied in boxes with 25 anodes.
- **DRIZORO® GALVAZINC-140**. Cylindrical zinc anodes of 140 grams weight, 12 cm length and

12 mm diameter, supplied in boxes with 25 units.

In addition to the zinc nodules, the system includes connectors, conductor cables and the **DRIZORO® GALVAZINC BOND** electrolytic paste supplied in 350 ml cartridges.

## STORAGE

**DRIZORO® GALVAZINC** can be stored 24 months in its original closed container in a dry and covered place protected from direct sunlight, heat and humidity.

**DRIZORO® GALVAZINC BOND**: Twelve months in its original closed and undamaged cartridge. container in a dry and covered place protected from direct sunlight, heat and humidity, with temperatures above 5°C and below 40°C.

## SAFETY AND HEALTH

**DRIZORO® GALVAZINC** and **DRIZORO® GALVAZINC BOND** are not toxic products, but rubber gloves and safety goggles should be used during application. In case of eye contact, rinse immediately with plenty of clean water and without rubbing. In case of skin contact, clean with warm soapy water. If ingested, seek immediate medical attention, do not induce vomiting.

Safety Data Sheet for **DRIZORO® GALVAZINC** and **DRIZORO® GALVAZINC BOND** is available by request.

The disposal of the product and its packaging must be conducted in accordance with current legislation and is responsibility of the final consumer of the product

## TECHNICAL DATA

Product characteristics		
	DRIZORO® GALVAZINC-70	DRIZORO® GALVAZINC-140
Equivalent weight of Zn, (g)	70	140
Dimension of anodes, (length x diameter)	6 cm x 12 mm	12 cm x 12 mm
Protection effect zone (cm)	30	
Load capacity, (kC)	175	350
Application conditions for DRIZORO® GALVAZINC BOND		
Minimum application Temperature / Relative Humidity (°C/%)	>5 / <85	
Consumption*		
DRIZORO® GALVAZINC, standard anode spacing	60 cm between anodes and 5 cm from rebars	
DRIZORO® GALVAZINC BOND in 350 ml cartridge	15 anodes per each cartridge 350 ml	8 anodes per each cartridge 350 ml

\* Consumption may vary depending on rebars arrangement, the porosity and irregularities of the substrate, and the application method. Conduct an on-site test to determine the exact consumption

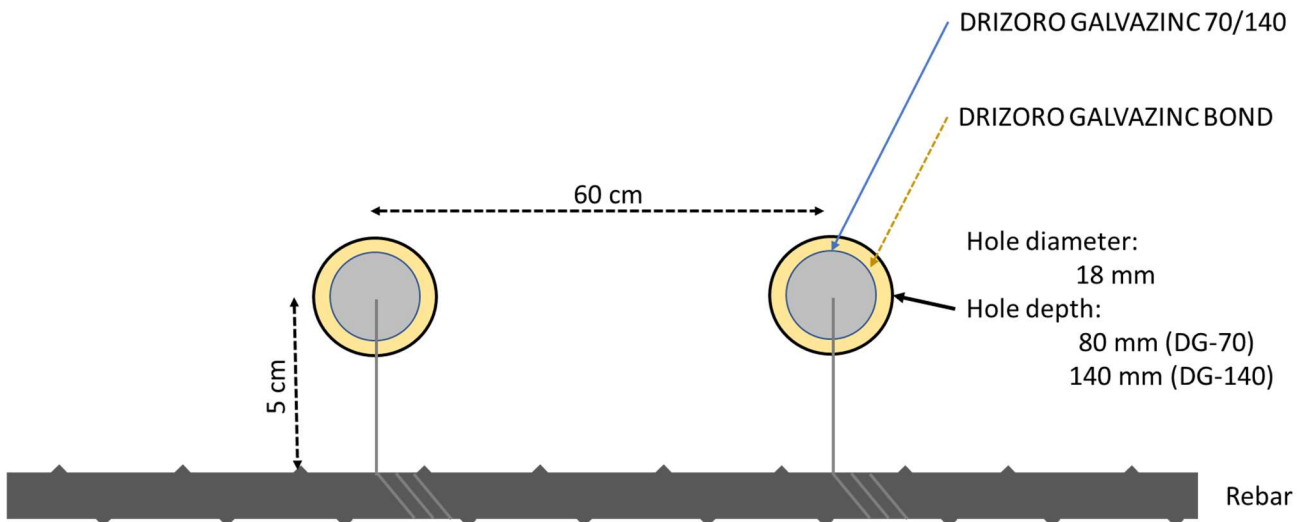

## GUARANTEE

The information contained in this leaflet is based on our experience and technical knowledge, obtained through laboratory testing and from bibliographic material. **DRIZORO®, S.A.U.** reserves the right to introduce changes without prior notice. Any use of this data beyond the purposes expressly specified in the leaflet will not be the Company's responsibility unless authorised by us. We shall not accept responsibility exceeding the value of the purchased product. The data shown on consumptions, measurement and yields are for guidance only and based on our experience. These data are subject to variation due to the specific atmospheric and jobsite conditions so reasonable variations from the data may be experienced. In order to know the real data, a test on the jobsite must be done, and it will be conducted under the client responsibility. We shall not accept responsibility exceeding the value of the purchased product. For any other doubt, consult our Technical Department. This version of bulletin replaces the previous one.